

TWGW-646 / WGW-646

FIXED ALUMINUM LOUVERS DRAINABLE

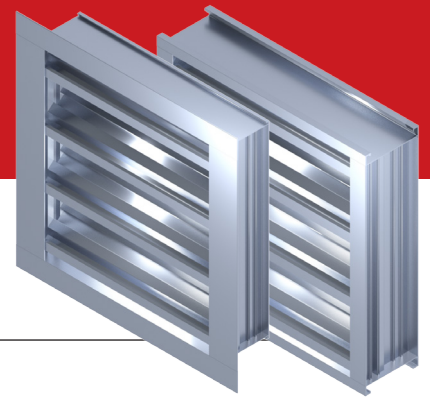

STANDARD CONSTRUCTION

FRAME	EXTRUDED 6063-T6 ALUMINUM, 0.125" (3.2 MM) THICK
BLADES	EXTRUDED 6063-T6 ALUMINUM, 0.125" (3.2 MM) THICK
BLADE ANGLE	46°
BLADE SPACING	± 6" (152.4 MM)
BLADE FASTENING	FASTENED TO FRAME WITH SCREWS
BIRD SCREEN	GALVANIZED 1/2" X 1/2" X 0.047" (12.7 MM X 12.7 MM X 1.2 MM)
FINISH	MILL
SINGLE SECTION	MIN. 12" (305 MM) X 16" (406 MM) MAX. 60" (1 524 MM) X 234" (5 944 MM)
MULTIPLE SECTIONS	VARIOUS CONFIGURATIONS AVAILABLE

PERFORMANCE: 48" X 48" SECTION

FREE AREA	6.94 FT ² (0.645 M ²)
PERCENTAGE OF FREE AREA	43%
BEGINNING POINT OF WATER PENETRATION	1 045 FT/MIN (5.31 M/S)
PRESSURE DROP AT BEGINNING POINT OF WATER PENETRATION	0.052" W.G. (13.0 PA)

NOTE: Louvers tested with bird screen installed

AVAILABLE OPTIONS

BIRD SCREEN	GALVANIZED 1/4" X 1/4" (6.35 MM X 6.35 MM)
	GALVANIZED 1" X 1" (25.4 MM X 25.4 MM)
	EXPANDED ALUMINUM 1/2" - 051F (12.7 MM)
INSECT SCREEN	FASTENED
	REMOVABLE
BLANK-OFF PANEL	NON INSULATED
	INSULATED AND FASTENED (WITH THERMAL BARRIER)
ACCESS LOUVER (DOOR)	INSULATED AND REMOVABLE (WITH THERMAL BARRIER)
	MOUNTED ON HINGES

FINISHES AVAILABLE

ANODIZED	CLEAR
	COLOR
PAINT	LECHLER ISOLACK (5-YEAR WARRANTY)
	DURANAR OR INTERPON D 2000 (20-YEAR WARRANTY)
	DURANAR XL OR INTERPON D 3000 (30-YEAR WARRANTY)

LOUVERS WITH UNINTERRUPTED BLADE LINE

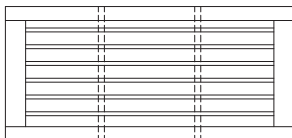

LOUVERS WITH VISIBLE MULLIONS

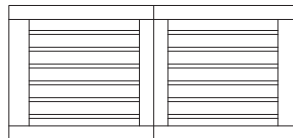

TWGW-646

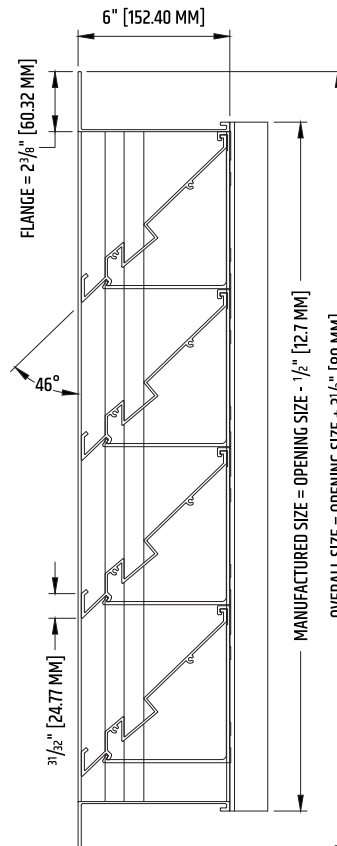

WGW-646

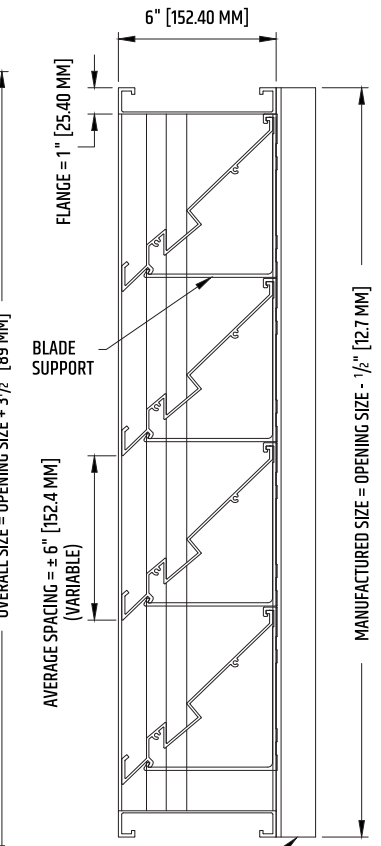

EXTERIOR FRAME OF FLANGED LOUVER

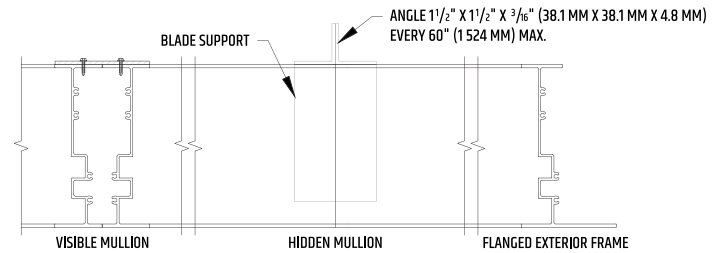

EXTERIOR FRAME OF INSERTED LOUVER (NO FLANGE)

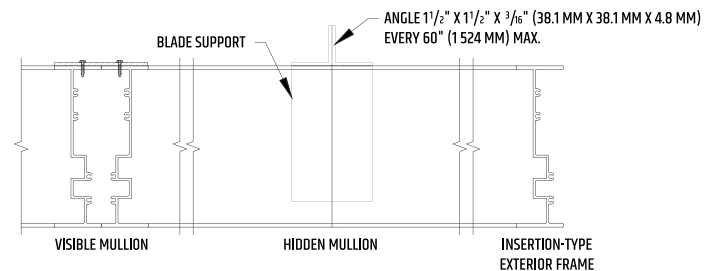

LOUVER FREE AREA (IN²)

HEIGHT (IN)	WIDTH (IN)										
	12	18	24	30	36	42	48	54	60	66	72
12	0.28	0.45	0.62	0.79	0.97	1.14	1.31	1.48	1.66	1.76	1.93
18	0.48	0.78	1.08	1.38	1.68	1.98	2.28	2.57	2.87	3.06	3.36
24	0.69	1.11	1.54	1.96	2.39	2.81	3.24	3.66	4.09	4.36	4.78
30	0.89	1.45	2.00	2.55	3.10	3.65	4.20	4.75	5.31	5.65	6.20
36	1.10	1.78	2.45	3.13	3.81	4.49	5.17	5.85	6.52	6.95	7.63
42	1.27	2.05	2.83	3.61	4.39	5.17	5.95	6.73	7.52	8.00	8.78
48	1.48	2.39	3.30	4.21	5.12	6.03	6.94	7.85	8.77	9.34	10.25
54	1.68	2.72	3.76	4.80	5.84	6.88	7.92	8.96	10.00	10.65	11.69
60	1.89	3.06	4.23	5.40	6.57	7.74	8.91	10.07	11.24	11.97	13.14
66	2.10	3.40	4.70	6.00	7.30	8.60	9.90	11.20	12.50	13.31	14.61
72	2.31	3.74	5.17	6.60	8.03	9.46	10.89	12.31	13.74	14.64	16.06
78	2.53	4.08	5.64	7.20	8.76	10.32	11.88	13.44	15.00	15.97	17.53
84	2.74	4.43	6.12	7.81	9.50	11.19	12.88	14.57	16.26	17.32	19.01
90	3.02	4.89	6.75	8.61	10.48	12.34	14.21	16.07	17.94	19.10	20.97
96	3.23	5.22	7.21	9.20	11.20	13.19	15.18	17.17	19.16	20.41	22.40
102	3.44	5.56	7.68	9.81	11.93	14.05	16.17	18.30	20.42	21.75	23.87
108	3.65	5.90	8.15	10.40	12.65	14.90	17.15	19.40	21.65	23.05	25.30
114	3.86	6.24	8.62	11.00	13.38	15.76	18.14	20.52	22.90	24.39	26.77
120	4.07	6.57	9.08	11.59	14.10	16.61	19.12	21.63	24.14	25.71	28.22

NOTE: Louvers tested with bird screen installed

**PRESSURE DROP VS AIR VELOCITY
MODEL TWGW-646**

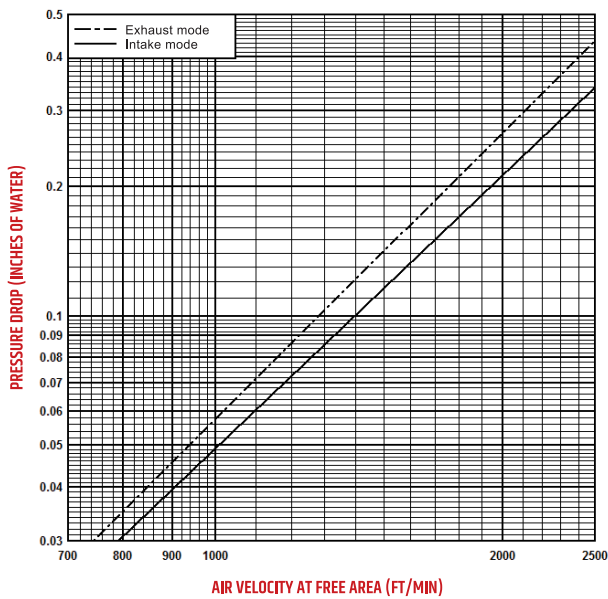

**WATER PENETRATION
MODEL TWGW-646
BEGINNING POINT OF WATER PENETRATION AT 1 045 FT/MIN**

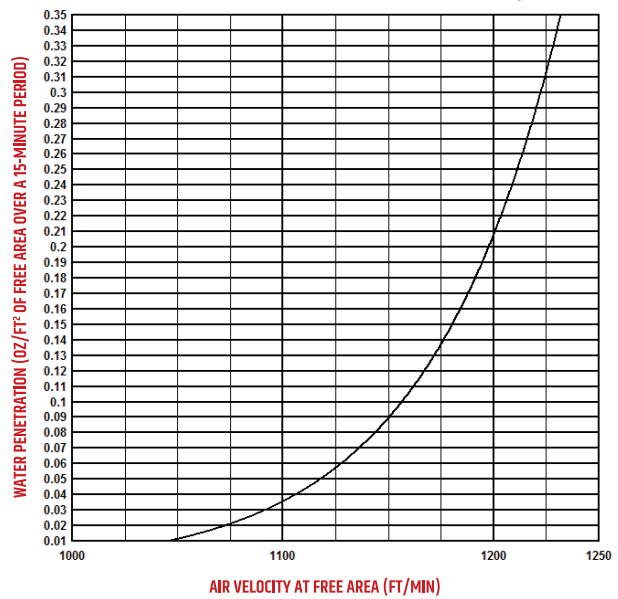

NOTE: Water penetration and pressure drop tests performed by Air-Ins Laboratories, in accordance with the AMCA 500 standard.

CALCULATION METHOD FOR REQUIRED FREE AREA

To determine the free area required for a louver:

- > Step 1: Divide the required flow (CFM) by the projected velocity at free area.
- > Step 2: Choose the desired louver size from the free area table that meets the minimum requirements.
- > Step 3: Compare specifications for certified water penetration and pressure drop.

Example for intake:

10 000 CFM flow at 600 FT/MIN :

$$\text{Min. free area} = \frac{\text{required CFM}}{\text{maximum projected velocity}^*} = \frac{10\,000}{600} = 16.7 \text{ ft}^2$$

Select a louver measuring 72" x 78" with 17.53 ft² of free area

* Should not exceed beginning point of water penetration speed.

Trolec reserves the right to modify these specifications without notice.